

GENERAL CHARACTERISTICS

In the case of instantaneous heaters, hot water flow has to at least meet the minimum flow required by heater and maintain burning.

(Specified by heater manufacture)

OPERATING SPECIFICATIONS

Hot water supply temperature:

Maximum: 85°C

Minimum: 5°C Higher than maximum required mixed temperature.

Advisable 65°C.

Minimum difference between hot and mixed temperature is 10°C.

Operating Pressure

Maximum 5 Bar

Minimum 0.1 Bar

Operating pressure (on hot and cold line) should be kept as balanced as possible in order to assure maximum efficiency.

When the pressure is higher than a 5 Bar a pressure reducer is required to be fitted before valve.

TECHNICAL DATA

This mixer is supplied with a cover plate, for installation depth see the reference on the cover.

The mixed temperature is preset at 38 degree Celsius.

The mixer ports can be supplied ¾ BSP and NPT threads.

PLUMBING RECOMMENDATIONS

- An independent water supply (both hot and cold) is required for the shower system please refer to installation diagrams.
- Large runs of pipe work will cause frictional loss of pressure.
- The recommended from both cylinder and water tank should be 22 mm minimum reducing to 15 mm within half a meter of valve.
- If more than one shower valve is installed the minimum feed from tank and cylinder should be 28 mm, reducing to 15 mm within half a meter valve. (Ensure adequate supply of both hot and cold water can be maintained).
- In installations where a pump is required, install pump before shower mixer inlets.

WATER BYE LAWS

The mixing valve should be installed in compliance with the water bye laws. For further details refer to the latest copy of water bye laws guide or your local water authority.

FITTING COVER PLATE

- Remove the protection from the mixer.
- Place the seal to the plate.
- Push chrome cover plate over the regulation knob.
- When in position, fit chromed adaptors against cover plate and on/off control handles and secure with the grub screws with 2,5 mm Alan key.
- Fit the caps on the handles.
- Check that temperature is at 38°C before shower is used.

CARTRIDGE CHANGE AND CLEANING

Through years of use impurities and limescale could restrict flow of water through the filters of the cartridge.

To clean it follow the instruction hereunder.

- Shut off water supply to both inlets.
- Remove the cap (1), remove grub screw(2) with 2,5 mm Alan key, take off temperature control handle (3) and plastic stop ring (4).
- Unscrew cartridge (5) using 30 mm spanner. Wash filters (6) under running water or leave to soak in vinegar or de-scaling agent.
- Before re-assembling cartridge (5) clean its housing with wet cloth and grease “O” rings on cartridge.
- Re-assembling cartridge (5) into body.
- Re-fit plastic stop ring (4) according to the drawing, align mark (A), turn spindle (A) until you reach required temperature 38°C.
- Re-fit temperature control handle (3). Test that mix temperature is set at 38°C.
- Re-fit the grub screw (2) and the cap (1).

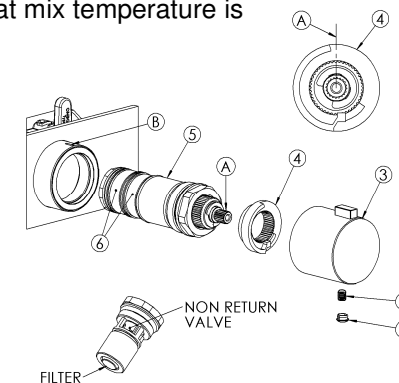

Servicing & Maint. Integrael Stop Check Valves with closure

Rotating the 2 screws on the stop/checks (for 7 turns clockwise) will shut off the water to the cartridge for service and maintenance. If you are experiencing a reduction of water flow to the mixer, you may have an obstruction of debris in the check valve or in the strainer at the bottom. Shut off the water for both the hot and cold at the main inlet; unscrew the check valve assembly with a 27mm wrench. Clear the strainer and the check valve of any debris and replace back into the inlets. Attention: screw the check valve exerting a max torque less than 8-10 Nm or 70-90 lbf•in