

THERMOSTATIC BUILT-IN SHOWER MIXER  
WITH TWO WAY DIVERTER AND 2 FLOW  
THROUGH VALVE 2 OULETS - CHROME



## GENERAL CHARACTERISTICS

The valve is suitable for all water heating systems provided it is installed correctly by a competent and qualified installer. Please refer to installation diagrams. In the case of instantaneous heaters, hot water flow has to at least meet the minimum flow required by heater and maintain burning. (Specified by heater manufacture).

## OPERATING SPECIFICATIONS

Hot water supply temperature:

Maximum: 85°C

Minimum: 5°C Higher than maximum required mixed temperature.  
Advisable 65°C

Minimum difference between hot and mixed temperature is 10°C

## Operating Pressure

Maximum: 5 Bar

Minimum: 0.1 Bar

Hot and Cold Operating pressure should be kept as balanced as possible in order to maintain maximum efficiency.

When the supply pressure is higher than a 5 Bar a pressure reducing valve should be fitted before the shower valve.

## TECHNICAL DATA

The mixer is supplied with a chromium-plated cover plate for installation depth from 65mm to 85mm. The temperature control knob is preset at 38°C with auto stop at 43°C to avoid scalding.

The mixer ports are supplied ¼ BSP threads.

The valve is provided with an additional outlet at base of the valve (for bath filler).

When using the bottom outlet a flow control is required. Fit a stop valve between valve outlet and delivery point. The bottom outlet is sealed with a removable plug.

## PLUMBING RECOMMENDATIONS

- ◆ An independent hot and cold water supply is required for the shower system please refer to installation diagrams.
- ◆ Large runs of pipe work will cause frictional loss of pressure.
- ◆ The recommended pipe work from both cylinder and water tank should be 22mm minimum.
- ◆ If more than one shower valve is installed the minimum feed from tank and cylinder should be 28mm. (Ensure adequate supply of both hot and cold water can be maintained).

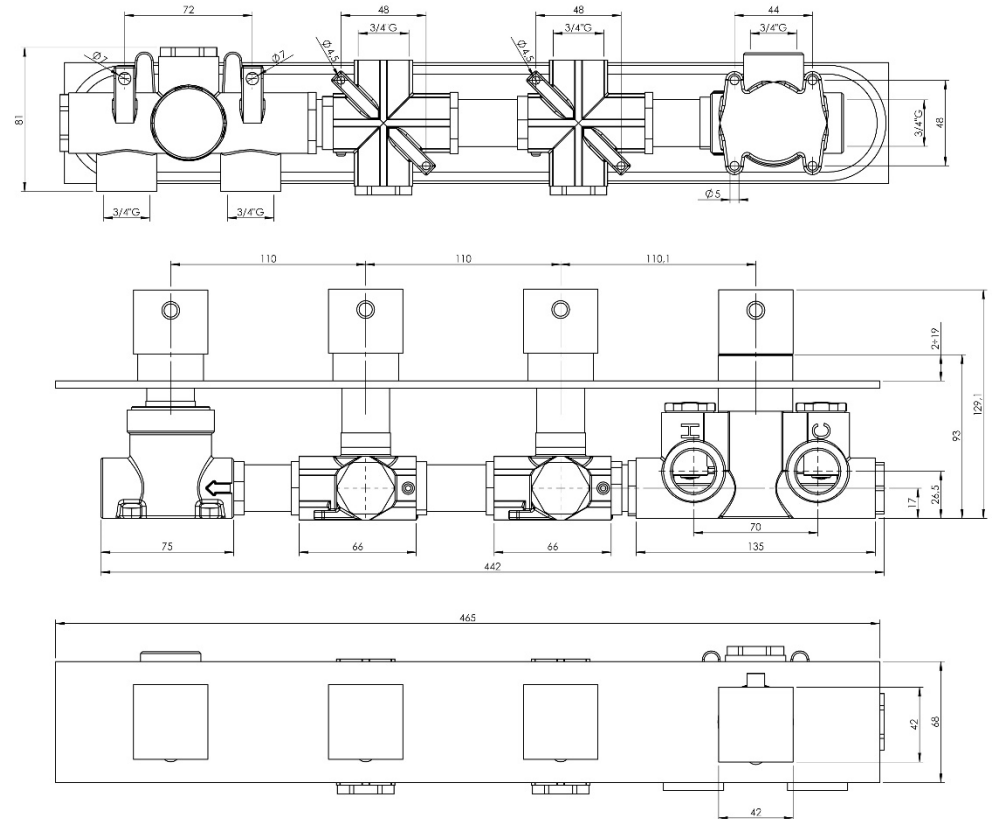

## IMPORTANT – CARE OF YOUR PRODUCT CLEANING

After use all finishes should be maintained by wiping with a soft, damp, clean cloth and then polished using a dry duster. NO abrasive powder, detergents or polishes should be used. Cleaner containing alcohol, acid or corrosive chemicals should not be used.

## NOTE

- ◆ Some household bleaches and denture cleaners can damage plated or coloured finishes and if splashed onto a fitting should be immediately washed off with cold water.
- ◆ If these instructions are followed we believe this fitting will give many years of satisfactory use.
- ◆ We have a policy of continuous improvement and reserve the right to change specification without notice.
- ◆ In case of prolonged disuse of the mixer in winter time, it is recommended to close the system and empty the mixer to avoid damages caused by frost.

## GUARANTEE

The shower valve is guaranteed for a period of 5 years against any defects of materials and workmanship from date of purchase, subject to correct installation, maintenance and use in accordance with this instruction leaflet. Please retain proof of purchase.

During the guarantee period parts will be replaced or repaired at our option. No labour costs will be reimbursed unless prior agreement has been obtained from the factory.

This guarantee is offered as an extra benefit and does not affect your statutory rights as a consumer in any way whatsoever.

## WATER BYE LAWS

The mixing valve should be installed in accordance with the water bye laws. For further details refer to the latest copy of Water Bye Laws guide or your local water authority.

## FITTING COVER PLATE

- Remove the protection from the mixer.
- Place the seal sponge to the plate.
- Push chrome cover plate over the valve.
- When in position, fit chromed adaptors against cover plate and on/off control handles and secure with the grub screws with 2,5 mm Alan key.
- Fit temperature control handle and secure with the grub screw with 2,5 mm Alan key.
- Fit the cap on the handles.
- Check that temperature is at 38°C before shower is used.

## CARTRIDGE CHANGE AND CLEANING

Through years of use impurities and limescale could restrict flow of water through the filters of the cartridge.

To clean it follow the instruction hereunder.

- Shut off water supply to both inlets.
- Remove the cap (1), remove grub screw (2) with 2,5 mm Alan key, take off temperature control handle (3) and plastic stop ring (4).
- Unscrew cartridge (5) using 30 mm spanner. Wash filters under running water or leave to soak in vinegar or de-scaling agent.
- Before re-assembling cartridge (5) clean its housing with wet cloth and grease "O" rings on cartridge.
- Re-assembling cartridge (5) into body.
- Re-fit plastic stop ring (4) according to the drawing, turn spindle (A) until you reach required temperature 38°C.
- Re-fit temperature control handle (3). Test that mix temperature is set at 38°C.
- Re-fit the grub screw (2) and the cap (1).

## Serving & Maint. Integrael Stop Check Valves with closure

Rotating the 2 screws on the stop/checks (for 5 turns clockwise) will shut off the water to the cartridge for service and maintenance. If you are experiencing a reduction of water flow to the mixer, you may have an obstruction of debris in the check valve or in the strainer at the bottom. Shut off the water for both the hot and cold at the main inlet; unscrew the check valve assembly with a 27mm wrench. Clear the strainer and the check valve of any debris and replace back into the inlets. Attention: screw the check valve exerting a max torque less than 8-10 Nm or 70-90 lbf•in

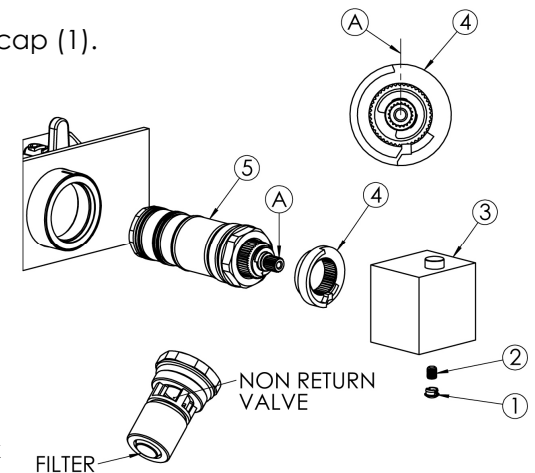

## MAINTENANCE – DIVERTER CARTRIDGE CHANGE

To remove the diverter cartridge:

- ◆ Shut off water supply to both inlets.
- ◆ Remove the caps (1), remove grub screws (2) with 2,5 mm Alan key and take off the knobs (3).
- ◆ Unscrew the screws(4) and remove the brass bushes (5).
- ◆ Unscrew the adapters (6), attention not to lose the "O"-rings (7).
- ◆ Remove the cover plate(8).
- ◆ Unscrew the element (9) using 17mm spanner.
- ◆ Unscrew flange (10) using 17mm spanner.
- ◆ Remove the diverter cartridge (11).
- ◆ Before re-assembling cartridge clean its housing with wet cloth and grease "O" rings on cartridge.
- ◆ Place the cartridge, inserting the two pivots into the corresponding seats.
- ◆ Re-fit flange(10), reassemble the element (9).
- ◆ Re-fit the cover plate (8).
- ◆ Screw the adapters (6) with "O"-rings (7).
- ◆ Re-fit the brass bushes(5) and secure with the screws(4).
- ◆ Re-fit the knobs(3) the grub screws (2) and the caps (1).

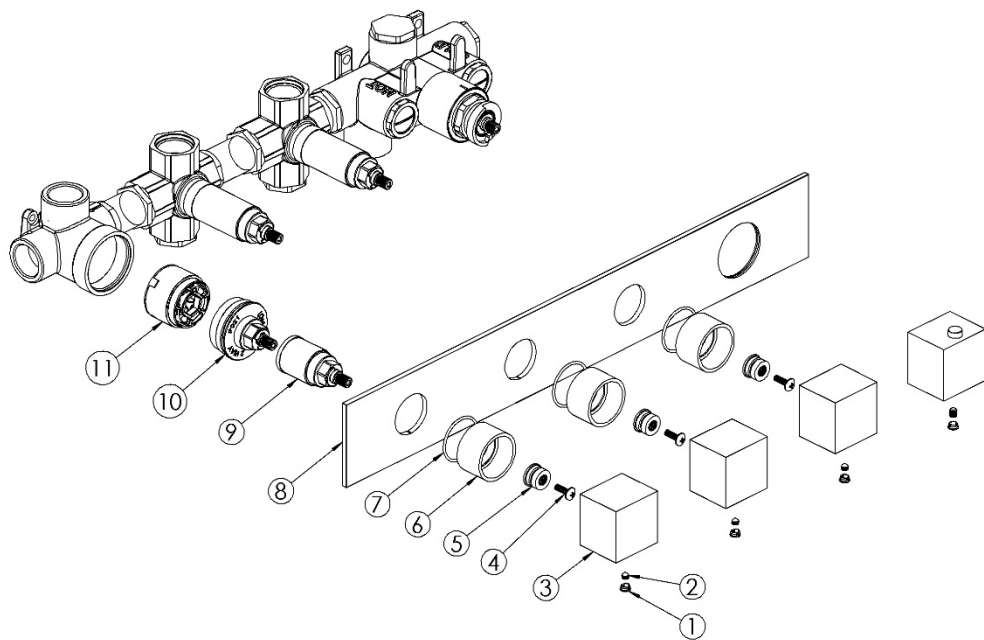

## VERTICAL REGULATION OF THE DIVERTER HANDLE

If diverter handle, top handle, is not perfectly lined up with the vertical, following the procedure:

- ◆ Shut off both inlets water supply.
- ◆ Remove the cap(3), remove the grub screws(2) with a 2,5 mm Alan key, remove the diverter knob (1).
- ◆ Re-fit the diverter handle in to the vertical position and secure with grub screws(2).
- ◆ Re-fit the cap(3).

